

# Design and development of MIRI, the mid-IR instrument for JWST

G.S. Wright<sup>a</sup>, G. Reike<sup>b</sup>, P. Barella<sup>c</sup>, T. Boeker<sup>d</sup>, L. Colina<sup>e</sup>, E. van Dishoeck<sup>f</sup>, P. Driggers<sup>g</sup>, G. Goodson<sup>c</sup>, T. Greene<sup>h</sup>, A. Heske<sup>d</sup>, T. Henning<sup>i</sup>, P-O. Lagage<sup>j</sup>, M. Meixner<sup>k</sup>, H. Norgaard-Nielsen<sup>l</sup>, G. Oloffson<sup>m</sup>, T. Ray<sup>n</sup>, M. Ressler<sup>c</sup>, J.Thatcher<sup>o</sup>, C. Waelkens<sup>p</sup>, D. Wright<sup>o</sup>, A.Zehnder<sup>q</sup>

<sup>a</sup>UK Astronomy Technology Centre, Blackford Hill, Edinburgh EH9 3DJ, United Kingdom

<sup>b</sup>Steward Observatory, University of Arizona, 933 N. Cherry Avenue, Tucson, AZ 85721-0065  
U.S.A

<sup>c</sup>Jet Propulsion Laboratory, California Institute of Technology, 4800 Oak Grove Drive, Pasadena, CA 91109, USA

<sup>d</sup>ESTEC, 2200AG Noordwijk, Netherlands

<sup>e</sup>Consejo Superior de Investigaciones Científicas, Instituto de Estructura de la Materia, C/Serrano 121, 28006-Madrid , Spain

<sup>f</sup>Sterrewacht Leiden, Postbus 9513, 2300 RA Leiden , The Netherlands

<sup>g</sup>NASA Goddard Space Flight Centre, Greenbelt MD 20771, USA

<sup>h</sup>Nasa Ames Research Centre, Moffett Field, CA 94035, USA

<sup>i</sup>Max-Planck Institute für Astronomy, Königstuhl 17, 69117 Heidelberg, Germany

<sup>j</sup>CEA Saclay, Service d'Astrophysique, Orme de Merisiers, 91191 Gif-sur-Yvette CEDEX France

<sup>k</sup>Space Telescope Science Institute, 3700 San Martin Drive, Baltimore, MD 21218, USA

<sup>l</sup>Danish Space Research Institute, Juliane Mariesvej 30, DK-2100 Copenhagen, Denmark

<sup>m</sup>Stockholm Observatory, SCFAB Astronomy, SE-106 91, Sweden

<sup>n</sup>Dublin Institute for Advanced Studies, 5 Merrion Square, Dublin 2, Ireland

<sup>o</sup>EADS-Astrium Ltd, Gunnels Wood Road, Stevenage, SG1 2AS, United Kingdom

<sup>p</sup>Katholieke Univ. Leuven, Institut voor Sterrenkunde, Celestijnenlaan 200B, Heverlee 3001, Belgium

<sup>q</sup>Paul Scherrer Institute, Laboratory for Astrophysics, ODRA 120, 5232 Villigen-PSI , Switzerland

## ABSTRACT

MIRI is the mid-IR instrument for the James Webb Space Telescope and provides imaging, coronagraphy and integral field spectroscopy over the 5-28 $\mu$ m wavelength range. MIRI is the only instrument which is cooled to 7K by a dedicated cooler, much lower than the passively cooled 40K of the rest of JWST, which introduces unique challenges. The paper will describe the key features of the overall instrument design. The flight model design of the MIRI Optical System is completed, with hardware now in manufacture across Europe and the USA, while the MIRI Cooler System is at PDR level development. A brief description of how the different development stages of the optical and cooling systems are accommodated is provided, but the paper largely describes progress with the MIRI Optical System. We report the current status of the development and provide an overview of the results from the qualification and test programme.

**Keywords:** JWST, MIRI, mid-Infrared, coronagraph, spectrometer

## 1. INTRODUCTION

MIRI is one of four instruments to be built for JWST. It is being developed as a 50-50 partnership between the USA and Europe by JPL, a consortium of nationally funded European institutes, ESA and GSFC. The MIRI partnership was formed because of the enormous science potential of MIRI and each of the co-authors of this paper are representatives of the large instrument team. Testing of the MIRI Optical System verification model and environmental qualification of its major sub-assemblies has made significant progress, and as a result there are about a dozen papers presented at this SPIE

meeting describing final design details and test results. We provide in this paper an overview of the MIRI design and summarise the testing, with references to the more detailed papers as appropriate.

MIRI has capabilities needed for the whole range of JWST science, from the high redshift universe through the formation of planetary systems to our own solar system. The science goals of JWST are described in Gardner et al 2006<sup>1</sup> and are organized into the following four themes.

1. First Light (After the Big Bang): To find and study the first luminous objects - proto-galaxies, supernovae, black holes
2. Assembly of Galaxies: To study the merging of proto-galaxies, effects of black holes, history of star formation
3. Birth of Stars and Planetary Systems: JWST will study how stars form in dust clouds, and how chemical elements are produced and re-circulated.
4. Planetary Systems and the Origins of Life: To study the formation of planets and obtain direct observations of other planetary systems, as well as study of the outer solar system.

The science indicated very briefly above requires a versatile mid-infrared instrument covering the 5-28.5 $\mu\text{m}$  wavelength regime with a wide field of view for imaging through broad and narrow band filters, low resolution spectroscopy from 5-10 $\mu\text{m}$ , moderate resolution spectroscopy with  $R \sim 3000$ , and high dynamic range coronagraphy. MIRI is designed to provide all of these functions in a single instrument.

The MIRI imaging mode has a plate scale of 0.11 arcsec/pixel, fully sampling the JWST point spread function at 5.6 $\mu\text{m}$ , and a field of view of 1.7 by 1.3 arcminutes. There are 10 filters with centre wavelengths and bandpasses as indicated in table 1.

The MIRI coronagraphy mode has four coronagraphs operating at wavelengths selected optimally for the study of exoplanets (cf. Boccaletti et al <sup>2</sup>). The coronagraph band-passes are indicated by ‘‘C’’ in table 1.

Table 1. MIRI imaging and coronagraphy filter wavelengths and bandpasses

Name	Wavelength ( $\mu\text{m}$ )	Bandwidth ( $\mu\text{m}$ )	Name	Wavelength ( $\mu\text{m}$ )	Bandwidth ( $\mu\text{m}$ )
F560W	5.6	1.2	F2100W	21.0	5.0
F770W	7.7	2.2	F2550W	25.5	4.0
F1000W	10	2.0	F2550WR	25.5	4.0
F1130W	11.3	0.7	F1065C	10.65	0.53
F1280W	12.8	2.4	F1140C	11.4	0.57
F1500W	15.0	3.0	F1550C	15.5	0.78
F1800W	18.0	3.0	F2300C	23.0	4.6

The MIRI medium resolution spectroscopy mode is an integral field spectrograph with  $R \sim 3,000$  covering 4.6-28.6  $\mu\text{m}$ . The wavelength range has been divided into four channels with concentric fields of view on the sky, and each channel has 3 sub-bands having dedicated gratings, so that a complete spectrum of a 3.5 x 3.5 arcsec field of view can be obtained in 3 exposures. The details of spectral resolution, spatial resolution and fields of view for each of the spectrometer channels and the wavelength sub-bands are provided in table 2. For low resolution spectroscopy the resolution is  $R \sim 100$  with a 5 arcsec slit.

Table 2. MIRI spectroscopy channel wavelengths, fields of view, spectral and spatial resolutions and sampling.

Sub-band	Slice Width [μm]	Pixel Size [μm]	Field of View (arcsec)	Wavelength Coverage [μm]	Spectral Resolving Power (R = λ/Dλ)	Pixels per resolution element	
						Spectral	Spatial
1A	0.18	0.20	3.7 x 3.7	4.9 - 5.8	5180 - 6430	0.9 - 1.1	1.1 - 1.7
1B				5.6 - 6.7	4800 - 6600	0.9 - 1.2	1.2 - 1.6
1C				6.5 - 7.7	4770 - 6480	0.9 - 1.3	1.2 - 1.5
2A	0.28	0.20	4.5 x 4.7	7.5 - 8.8	2040 - 5590	1.1 - 3.1	1.2 - 1.7
2B				8.6 - 10.2	1770 - 5310	1.1 - 3.7	1.3 - 1.9
2C				10.0 - 11.8	1600 - 5000	1.2 - 4.1	1.5 - 2.2
3A	0.39	0.25	6.1 x 6.2	11.5 - 13.6	3070 - 5900	1.0 - 2.1	1.6 - 2.0
3B				13.3 - 15.7	2390 - 5510	1.1 - 2.2	1.9 - 2.3
3C				15.3 - 18.1	2150 - 5040	1.2 - 2.5	2.2 - 2.6
4A	0.64	0.27	7.9 x 7.7	17.6 - 21.0	2190 - 2510	1.7 - 2.1	2.2 - 2.7
4B				20.5 - 24.5	1950 - 2210	1.9 - 2.4	2.6 - 4.0
4C				23.9 - 28.6	1860 - 1950	2.2 - 2.7	3.1 - 3.7

## 2. MIRI DESIGN OVERVIEW

Due to the need to operate at mid-infrared wavelengths MIRI must be cooled to a temperature of 7K, much lower than the JWST observatory temperature of 40K. The instrument is therefore the only one of the JWST instruments to be cooled by a dedicated cooler and is thus unique in its distribution across all three regions of the spacecraft. This brings additional challenges for the instrument development. The overall MIRI design is shown schematically in figure 1, and the split of the overall system into two components, an Optical System and a Cooler System, is also shown.

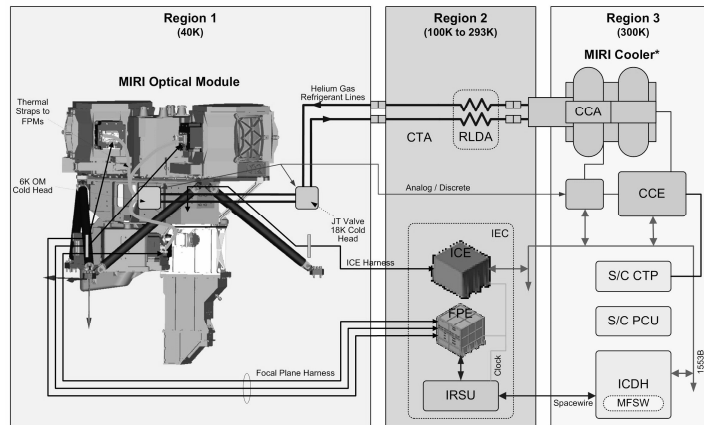

Figure 1. Overall schematic of the MIRI design

The MIRI Optical System and the MIRI Cooler System follow different development paths, and their technical development currently has different maturity levels:

The MIRI Cooler System passed PDR in February 2008. The demonstration model cooler was tested under representative conditions in the laboratory to demonstrate that it had reached TRL6. These tests included showing that the Cooler is capable of providing the heat lift required by the MIRI Optical System to reach its operating temperature of 6.7K. The Cooler is built, tested and integrated as a part of the Observatory as might be expected given the distribution of cooler hardware in figure 1. In particular the 6K cold head of the Cooler is delivered and integrated to the MIRI Optical System in the Integrated Science Instrument Module (ISIM) at GSFC in 2010, but the other cooler sub-systems are delivered and integrated with the JWST telescope and Observatory at later dates as they are required.

The MIRI Optical System completed CDR in May 2007. A flight-like “Verification Model” (VM) is currently undergoing cryogenic functional and science performance testing. The performance testing of the VM included showing that the expected heat load during cooldown in the JWST environment is within the heat lift capability of the Cooler System. The qualification programme at component and sub-assembly level is almost completed and flight model construction is now advancing rapidly. The flight model is delivered to GSFC in 2010 for integration and test in the ISIM along with all the other JWST instruments.

These necessarily separate development paths for the two halves of the system are accommodated by ensuring that there is a *very* clean and clear interface between the two systems. Mechanically there is a simple, single interface point of the MIRI Cooler heat-exchanger to MIRI Optical Bench, consisting of 2 x M5 screws. The thermal interface is defined in terms of the heat load in the steady state and transient cases and a defined interface temperature of < 6.2 K at the cold-head to MIRI structure attachment point.

### 3. KEY FEATURES OF THE MIRI OPTICAL SYSTEM

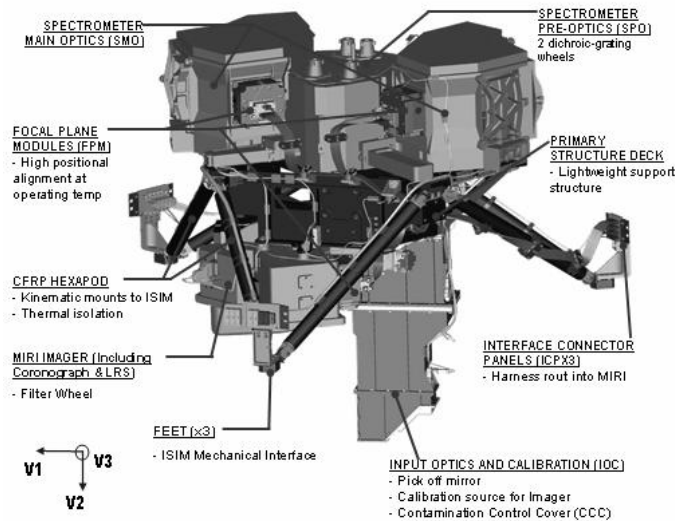

Figure 2 The MIRI OBA layout, and key subsystems (drawing courtesy of Jon Sykes, University of Leicester)

The MIRI Optical System includes the opto-mechanical system known as the optical bench assembly (OBA), an instrument control electronics (ICE) to drive the mechanisms, read temperature sensors etc, a focal plane control electronics (FPE) to drive the detectors and the MIRI flight software which configures and controls the instrument and handles the data flow between the hardware and the JWST ISIM flight software.

A CAD drawing of the MIRI OBA is shown in figure 2 with the main subassemblies identified. The instrument has a modular optical design and is an iso-thermal, homologous, all aluminium construction. The sub-assemblies have been designed to be testable “standalone”. The OBA is both supported on, and thermally isolated from, the ISIM structure by a CFRP hexapod. Isolation from the ISIM thermal environment is provided by custom designed MLI blankets which are not shown in the figure. These blankets and the overall thermal design are described in some detail in Shaughnessy et al 2008<sup>3</sup>.

Optically the instrument is divided into two channels – an imager channel, with one detector array and a spectrometer channel, which is further subdivided into long and short-wavelength modules each with a detector array. The fields of view for imaging and spectroscopy are defined and separated in the input optics and calibration sub-assembly, which also provides a calibration source for flat-field illumination of the imager. An identical calibration source is also included in the spectrometer channel. The imager optics are supported on one side of primary structure with the spectrometer optics on the other side, and all the mirrors and structures are light-weighted.

There are three wheel mechanism assemblies (Krause et al. <sup>4</sup>) based on ISO designs and heritage: one in the imager and one in each channel of the spectrometer. The imager wheel carries both the filters for imaging and the coronagraph masks/filters. Each spectrometer wheel mechanism assembly has a pair of wheels mounted on either side of the mechanism: a wheel with dichroics that define the sub-bands of the spectrometer, and a wheel with the matching set of gratings. There is also a contamination control cover (CCC) (Glauser et al. <sup>5</sup>) used to protect the MIRI detectors and optical chain from contamination in flight during the observatory cooldown process. The cover is also used to protect the detectors from saturation during the process of centering bright stars accurately behind the coronagraphic masks. The Instrument Control Electronics located in the warm spacecraft region 2 operates in cold redundancy and provides the capability to control the four mechanisms, process mechanism position sensor and thermistor telemetry, and drive the calibration emitters. The ICE is connected to the ISIM Command & Data-Handling electronics by an IEEE-1355 bus, and responds to instrument configuration commands from the MIRI Flight Software.

Each of the imager and short and long wavelength spectrometer modules has a Focal Plane Module (FPM) housing a single Sensor Chip Assembly (SCA) containing a 1024 x 1024 Si:As detector array with anti-reflective coatings applied to the detector to maximize the absorption for each instrument band and readout electronics. Details of the FPM design are provided in Kalyani et al<sup>6</sup> and Thelan et al<sup>7</sup>. The FPE is a space-qualified electronics box located in a room temperature compartment on the ISIM in Region 2, which responds to observation setup commands, produces the clocks and biases necessary to drive the detectors and read-out electronics, receives the analog signals from the detectors, amplifies and digitizes those signals, and transmits the science and housekeeping data to the JWST ISIM Command and Data Handling System (ICDH). It receives setup commands for the individual FPM SCAs from the MIRI flight software (FSW), which is an instrument-specific application within the JWST ICDH and its software hierarchy, communicating through a high speed SpaceWire interface. The FPE receives its power from the spacecraft Electrical Power Unit (EPU). The FPE also monitors and controls the temperature of each FPM and controls the detector annealing heaters which may be used to help remove the effects of latent images.

#### **4. CURRENT STATUS OF THE MIRI OPTICAL SYSTEM DEVELOPMENT**

To meet the aggressive schedule for the JWST instruments, the MIRI development plan has been based around 3 integrated models, with the two early developments mitigating key risk areas, and qualification models at unit and opto-mechanical sub-assembly level. This overall plan is shown schematically in figure 3, where it can be seen that the schedule for completion of the qualification testing overlaps with that of the FM integration.

The Structure Thermal Model (SM/STM) provided an early mechanical qualification of the Primary Structure and enabled test levels for qualification of sub-assemblies to be derived. The SM characterisation of gravity release and alignment repeatability warm to cold (77K) confirmed the overall design. The STM thermal balance and other cryo-testing was used to de-risk test facility development prior to VM, and the instrument thermal model correlation with the test results led to a revised and novel design of the MLI blankets [3] to improve their efficiency. The STM will be refurbished later this year and delivered to GSFC for use during the ISIM engineering testing.

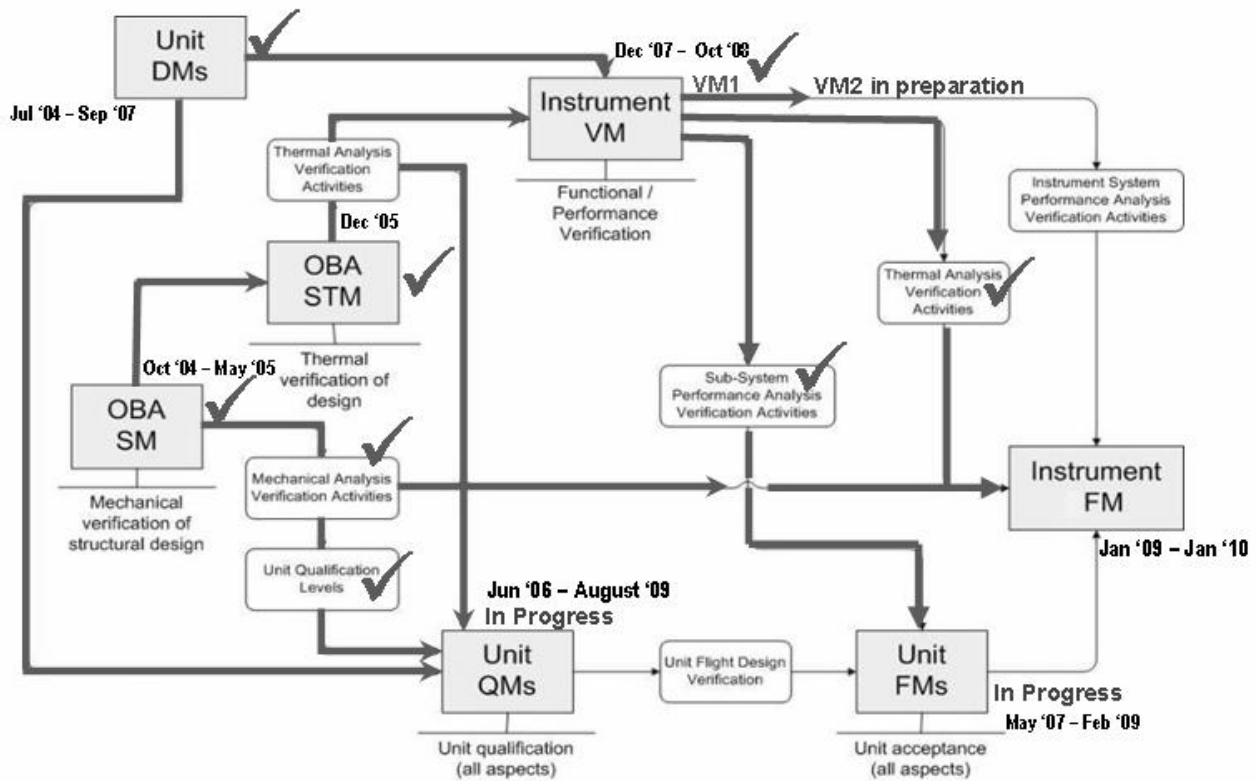

Figure 3 Schematic of the MIRI OS development plan showing progress

The Verification Model (VM) is used to verify early some key aspects of instrument science performance at operating temperature and to qualify the thermal aspects of the MLI blanket design. It contains the flight optical design (not fully populated with filters and only the short wavelength channel of the spectrometer has mirrors), working DM mechanisms, and a complete Focal Plane System with flight-like detectors and software. End-end instrument testing with a point-source stimulator has just been completed, and as described below all indications are that the FM instrument will meet requirements. The first VM cryo-test campaign has recently been completed. The VM test programme will be used to develop and finalise all the test procedures and test scripts for the FM verification and calibration programme, and the second VM cryotest campaign will therefore use the MIRI Telescope Simulator (MTS). The MTS has been developed for the flight verification, characterisation and ground calibration of MIRI Optical System and has the capability to: control illumination temperature; scan point sources within and outside the MIRI field of view; perform focus scans; enable polarisation measurements; provide “emission line” illumination for the spectrometer; and uniformly illuminate both the imager and spectrometer fields of view. The design and test/verification status of the MTS is presented in Belenguer et al.<sup>8</sup>

As each unit or sub-assembly is completed a formal review of its qualification status is held to confirm that all necessary environmental and parts qualification testing has been passed satisfactorily and adequately documented. Just over half of the planned sub-assembly and unit qualification reviews have been held to date.

The FM build of the MIRI Optical System is making very good progress – a number of key subsystems are either delivered or very close to delivery, including the primary structure, spectrometer main optics, contamination control cover/mechanism, electrical harnesses. Integration of the flight wheel mechanism assemblies has begun, and mirror manufacturing and optics housings are well advanced. All of the flight and flight spare focal plane arrays have been

selected by the MIRI science team. As described in Ressler et al.<sup>9</sup> these are excellent mid-IR detectors – cosmetically superb with dark currents at least as low as 0.2e/sec and read noise of the order of 15e coupled with a well depth of 250,000e.

## 5. PERFORMANCE TEST RESULTS

As would be expected given the current status of the development outlined in figure 3, test results supporting the design of MIRI have now been obtained at component, sub-assembly and integrated instrument level and many of these test results are presented in other papers at this meeting. The design and testing of the MIRI mechanisms is presented in [4] and [5], the prism for low resolution spectroscopy in [10] and [11], optical blacks in [12] and the detector performances and focal plane system in [6], [7] and [9].

We present here a short summary of test results of immediate relevance to the eventual scientific capability of the instrument. For these aspects the MIRI testing was based on two complementary test campaigns – of the VM instrument and of the MIRI imager channel. The VM instrument testing was carried out with a complete MIRI optical chain and the test illumination used a point source in a cold environment that represents the expected JWST 40K background. The MIRI imager (MIRIM-ETM) testing used a warm telescope simulator but included use of a distortion grid to verify the optical performance across the whole field of view and a detailed investigation of the coronagraph rejection. The qualification programme for the imager and the performance test results are described in detail in Amiaux et al.<sup>13</sup>. The analysis of the coronagraph test data and comparison with the models of the expected performance for the phase-mask coronagraphs is presented in Cavarroc et al.<sup>14</sup>, while the assessment of the Lyot coronagraph performance is in work.

The test chamber and test equipment for the MIRI VM cryo-test campaign, the tests carried out and all the preliminary test results are described in Lim et al.<sup>15</sup>. Although various detailed points were identified for follow-up in the flight design or flight test procedures, overall the instrument and test chamber performed very well. “Lessons learned” for the implementation of the FPE and ICE have already been implemented for flight. The basic adequacy of the design and test procedures for achieving MIRI science requirements has been confirmed by the combination of the MIRI SM/STM, MIRIM-ETU and MIRI VM test campaigns in all of the following areas:

- Imager, spectrometer and coronagraph optical performances
- Mechanisms functionality (CCC and Wheels)
- MLI blankets and thermal loads to the MIRI Cooler
- MIRI Flight Software
- MIRI Data Handling and Analysis Software (DHAS)
- Detector and pickoff mirror heaters performance and control
- Electrical harnesses
- On-board Calibration source illumination and control
- ICE
- FPE
- Overall mechanical stability and alignment to the telescope references
- Test Scripts
- Science Instrument Test Set (GSE) installed and methods of updating software demonstrated
- Test chamber performance (including temperatures, monitoring etc)

As described in [15] and [13], the measured image quality (full width half-maximum and encircled energy) of the imager and the measured distortion across the field of view are within specifications, giving good confidence in the expected

flight performance. The illumination source used for the VM test had previously had its brightness calibrated as a function of the drive current as part of the qualification programme for the flight calibration sources. This meant that it was possible to derive a preliminary comparison of the measured imager throughput compared to the expectation based on the optical modeling, detector and filter test data. Figure 4 shows that the transmission is flight-like within the errors of measurement.

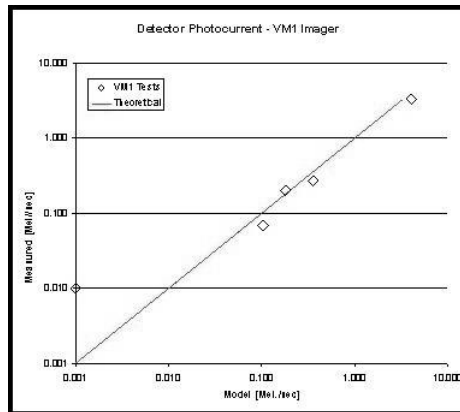

Figure 4 Comparison of model and measured imager throughput (graph courtesy of Alistair Glasse, UK-ATC)

The single, fixed location point source used for the VM MIRI testing meant that point source illumination of the spectrometer was not possible. However the on-board spectrometer calibration source for the spectrometer was used to provide flat-field illumination of the spectrometer, and from analysis of these images it is similarly possible to conclude that the spectrometer throughput is as expected, and there are no very large image quality or stray light issues<sup>15</sup>. The positions of the continuum spectra on the detector and their degree of curvature match the optical models very well. Three slices in the channel 2 data show the expected consequences of a deliberate change of size of the pupil mask that was made for test purposes. In addition the observed background variation as a function of wavelength is as expected, and the intra-slice regions are dark, so no major scattered light problems are evident.

As described in Cavarroc et al<sup>14</sup>, the MIRI phase mask coronagraph also worked as expected to within the measurement errors. For a source centred on the 10.65 $\mu$ m phase-mask a total rejection of 250 was measured, consistent with the models allowing for the finite size of the source and noise limitations.

Incorporating the preliminary test data in the end-end model of expected MIRI sensitivity for the imager and spectrometer indicates that for both the imager and spectrometer the requirements will be met.

## 6. CONCLUSIONS

The MIRI instrument is now well into the flight hardware construction phase, and the instrument development is making steady progress. Very successful end-end cryogenic performance tests of a flight-like verification model demonstrate that there is basically a working instrument now undergoing extensive testing. The data obtained will now be used to refine the FM test plans and for the MIRI science team to develop further the ground calibration and pipeline algorithms. Although the MIRI development still has some challenges ahead to complete the environmental qualification programme, the team can look forward on a solid basis to an instrument that is capable of meeting expectations and enable an exciting science programme.



## 7. ACKNOWLEDGEMENTS

The authors would like to acknowledge the innumerable contributions of the entire MIRI team to the results presented here, in their designing, building and testing the MIRI instrument models. In addition we thank everyone for the good spirit and enthusiasm within the MIRI partnership

The MIRI European Consortium thanks the following National Funding Agencies for their support of the MIRI: Belgian Science Policy Office, Centre Nationale D'Etudes Spatiales, Danish National Space Centre, Deutsches Zentrum fur Luft- und Raumfahrt, Enterprise Ireland, Ministerio De Education y Ciencia, Nova, Science and Technology Facilities Council, Swiss Space Office, Swedish National Space Board.

MIRI draws on the expertise of the following organisations: Ames Research Center, USA; Astron, Netherlands Foundation for Research in Astronomy; CEA Service d'Astrophysique, Saclay, France; Centre Spatial de Liège, Belgium; Consejo Superior de Investigaciones Científicas, Spain; Carl Zeiss Optronics, Germany; Danish Space Research Institute, Denmark; Dublin Institute for Advanced Studies, Ireland; EADS Astrium Ltd., UK; European Space Agency, Netherlands; ETCA, Belgium; Goddard Space Flight Center, USA; Institut d'Astrophysique Spatiale, France; Instituto Nacional de Técnica Aeroespacial, Spain; Institute of Astronomy, Zurich, Switzerland; Jet Propulsion Laboratory, USA; Laboratoire d'Astrophysique de Marseille (LAM), France; Lockheed Advanced Technology Center (USA); Max-Planck Institut für Astronomie (MPIA), Heidelberg, Germany; Observatoire de Paris, France; Observatory of Geneva, Switzerland; Paul Scherrer Institut, Switzerland; Physikalishes Institut, Bern, Switzerland; Raytheon Vision Systems, USA; RUAG Aerospace, Switzerland; Rutherford Appleton Laboratory (RAL), UK; Space Telescope Science Institute, USA; Toegest-Natuurwetenschappelijk Onderzoek (TNO-TPD), Netherlands; UK Astronomy Technology Centre (UKATC), UK; University College London, UK; Univ. of Amsterdam, Netherlands; Univ. of Arizona, USA; Univ. of Cardiff, UK; Univ. of Cologne, Germany; Univ. of Groningen, Netherlands; Univ. of Leicester, UK; Univ. of Leiden, Netherlands; Univ. of Leuven, Belgium; Univ. of Stockholm, Sweden, Utah State Univ., USA;

## REFERENCES

- [1] Gardner, J.P., Mather, J.C., Clampin, M., Doyon, R., Greenhouse M.A., Hammel, H.B., Hutchings J.B., Jakobsen, P., Lilly, S.J., Long, K., Lunine, J.I., McCaughrean, M.J., Mountain, M., Nella, J., Rieke, G.H., Rieke, M.J., Rix, H-W., Smith, E.P., Sonneborn, G., Stiavelli, Stockman, H.S., Windhorst, R.A., Wright, G.S. "The James Webb Space Telescope, *Space Science Reviews*, 123, no4 (2006).
- [2] Boccaletti et al. *ASR* 36, 1099 (2006)
- [3] B. M. Shaughnessy and P. Eccleston. "Thermal Design of the Mid-Infrared Instrument (MIRI) for the James Webb Space Telescope". International Conference on Environmental Systems (ICES), 29 June -2 July 2008, San Francisco, California, USA.
- [4] Krause, O., Hofferbert, R., Henning, T.F.E., Lemke, D., Grozinger, U., Huber, A., Scheithauer, S., Boehm, A., Ebert, M., Rohloff, R-R., Blumchen, T., Gross, T., Ubele, M., Stein, C., Stott, R., Luichtel, G., Augueres, J-L., Amiaux, J., Jager, R., Meijers, M., Parr-Burman, P., Wright, G.S, Zehnder, A., Glauser, A. "Cryogenic wheel mechanisms for the mid-infrared instrument (MIRI) of the James Webb Space Telescope (JWST): detailed design and test results from the qualification program" in [Advanced Optical and Mechanical Technologies in Telescopes and Instrumentation], Proc. SPIE, Marseille, France, June 2008
- [5] Glauser, A.M., Langer, U., Zehnder, A. "The contamination Control Cover for the JWST mid-infrared instrument" in [Advanced Optical and Mechanical Technologies in Telescopes and Instrumentation], Proc. SPIE, Marseille, France, June 2008
- [6] Kalyani, S., Thelen, M., Cho, H., Ressler, M. "Development of a focal plane module for JWST/MIRI" in [High Energy, Optical, and Infrared Detectors for Astronomy III], Proc. SPIE, Marseille, France, June 2008
- [7] Dotson, J.L., McKelvey, M.E., McMurray, R.E., Ressler, M. "Dark current and radiation environment performance of a JWST/MIRI focal plane array", in [High Energy, Optical, and Infrared Detectors for Astronomy III], Proc. SPIE, Marseille, France, June 2008
- [8] Belenguer, T., Diaz, E., Aricha, A., Figueroa, I., Alcacera, M.A., Canchal, M., Colombo, M., "MIRI telescope simulator (MTS)" in [Space Telescopes and Instrumentation 1: Optical, Infrared and Millimeter Wave] Proc. SPIE, Marseille, France, June 2008

- [9] Ressler, M., Cho, H., Lee, R., and Sukhatme, K., “Performance of the JWST/MIRI Si:As detectors”, in [High Energy, Optical, and Infrared Detectors for Astronomy III], Proc. SPIE, Marseille, France, June 2008
- [10] Fischer, S., Rossi, L., Moratschke, D., Straubmeier, C., Eckart, A., Mazy, E., Renotte, E., Amiaux, J. “The JWST MIRI double-prism, design, and science drivers”, in [Space Telescopes and Instrumentation 1:Optical, Infrared and Millimeter Wave] Proc. SPIE, Marseille, France, June 2008
- [11] Rossi, L., Ninane, N., Mazy, E., Plessaria, J-Y.D., Renotte, E., Wielands, M., Fisher, S., Straubmeier, C., Dubreil, D., Amiaux, J., Poupar, S., Ronayette, S. “Manufacturing and verification of ZnS and Ge prisms for the JWST MIRI imager”, in [Advanced Optical and Mechanical Technologies in Telescopes and Instrumentation], Proc. SPIE, Marseille, France, June 2008
- [12] Meigner, F., Amiaux, J., Bouzat, M., Lanternier, T., Falcolini, M. “Qualification of stray light reduction surface treatment: Black Meudon”, in [Advanced Optical and Mechanical Technologies in Telescopes and Instrumentation], Proc. SPIE, Marseille, France, June 2008
- [13] Amiaux, J., Alouadi, F., Augueres, J-L., Bouchet, P., Bouzat, M., Cavarroc, C., Cloue, C., De Antoni. P., Desforge, D., Donati,A., Dubreuil,D., Eppelle, D., Gougnaud,F., Hervieu, B., Lagage, P-O., Leboeuf, D., Le Mer,I', Lussignol,Y., Mattei,P., Meigner, F., Moreau, V., Pantin,E., Perrin,P., Ronayette,S., Tauzin,G., Poupar,S., D. Wright,D., Glasse,A., Wright,G., Mazy,E., Plessaria,J.Y., Renotte,E., Ray,T., Abergel,A., Guillard,P., Y. Longval,Y., Ressler,M., Reess, J.M., Hofferbert, R., Krause,O., Justtanont,K., Olofsson. G. “Development approach and first infrared test results of the JWST/mid-infrared imager optical bench”, in [Space Telescopes and Instrumentation 1:Optical, Infrared and Millimeter Wave] Proc. SPIE, Marseille, France, June 2008
- [14] Cavarroc, C., Amiaux, J., Baudoz, P., Boccaletti, B., Bouchet, Dubreil, D., Lagage, P-O., Moreau, V., Pantin, E., Reess, J-M., Royanette, S., Wright, G.S. “First test results of the coronagraphic device of MIRI/JWST” in in [Space Telescopes and Instrumentation 1:Optical, Infrared and Millimeter Wave] Proc. SPIE, Marseille, France, June 2008
- [15] Lim, T., Alvarez, J.L., Bauwens, E., Bedregald, A.G., Blommaert, J., Dannerbauere, H., Eccleston, P., Ferlet,M., Fischer, S., Garcia-Marin, M., Glasse, A., Glauser, A.M., Gordon,K., Greene,T., Grundy, T., Hennemanne, M., Klaase,U., Labiano,A., Lahuis,F., Martinez, J.F., Merin, B., Morrison,J., Nakos,T., O’Sullivan,B., Pindor,B., Ressler, M., Shaughnessy,B., Vandenbussche, B., Wells,M., Wright, G., Zuther, J., “First Results from MIRI Verification Model Testing”, in [Space Telescopes and Instrumentation 1:Optical, Infrared and Millimeter Wave] Proc. SPIE, Marseille, France, June 2008